



Project Administration Department

324 East Pine Street
Tarpon Springs FL 34689
(727) 942-5638

Memorandum

Date: November 15, 2022
To: Mayor and Board of Commissioners
Through: Mark LeCouris, City Manager
From: Bob Robertson, Project Administration Department Director
Subject: Pinellas County Update on Beckett Bridge Replacement Project

Overview

Pinellas County's Project Manager will present a brief update on the status of the Beckett Bridge Reconstruction Project to the City Board of Commissioners on November 15, 2022 at the Regular Session Meeting.

Summary

City staff has been working with Pinellas County to accommodate its proposed replacement project for the Beckett Bridge. This large project proposes a complete reconstruction of the bridge, bridge approach, and significant stormwater drainage improvements on both sides of the bridge.

The attached presentation will be given by Ann Venables, Pinellas County Project Manager in the Capital Improvements Division.



Beckett Bridge Replacement & Riverside Drive Drainage Improvements Status Update

Tarpon Spring City Commission Meeting, November 15, 2022

Ann Venables, Public Works/Capital Improvements Division

Project Limits - Bridge Replacement

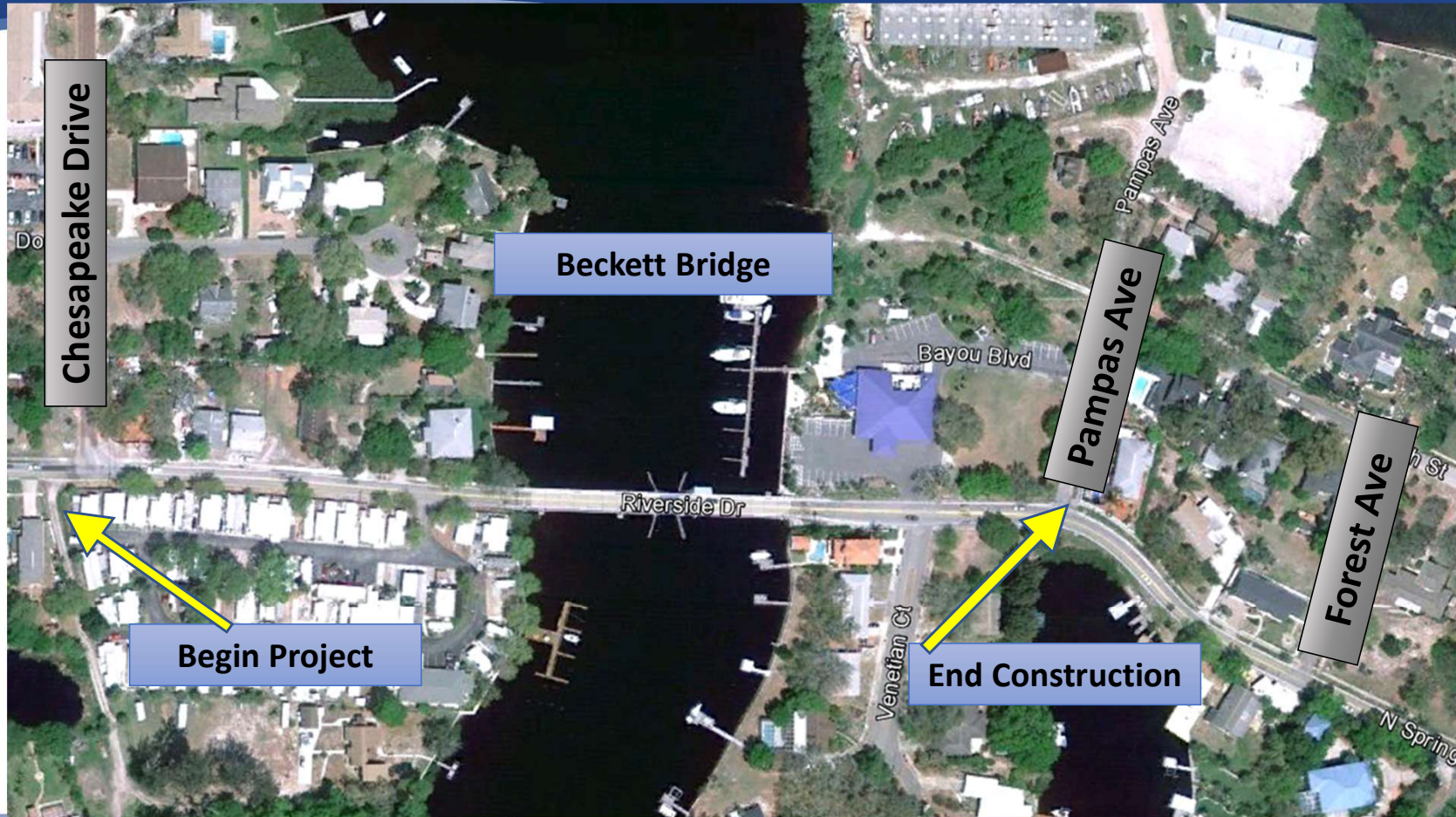

Project Limits – Riverside Drive Drainage Improvements



Riverside Drive Drainage Improvements



- Improve Drainage
- Reduce on-street flooding
- Collect roadway runoff with additional drainage structures
- Runoff will outfall into Kreamer Bayou
- Construction concurrent with Bridge Replacement

Existing Bridge

- Vertical Clearance: 6 ft (in closed position)
- Horizontal Clearance: 25 feet
- Structurally Deficient
- Functionally Obsolete
 - Bridge geometry does not meet current standards
 - Very narrow
 - No shoulders

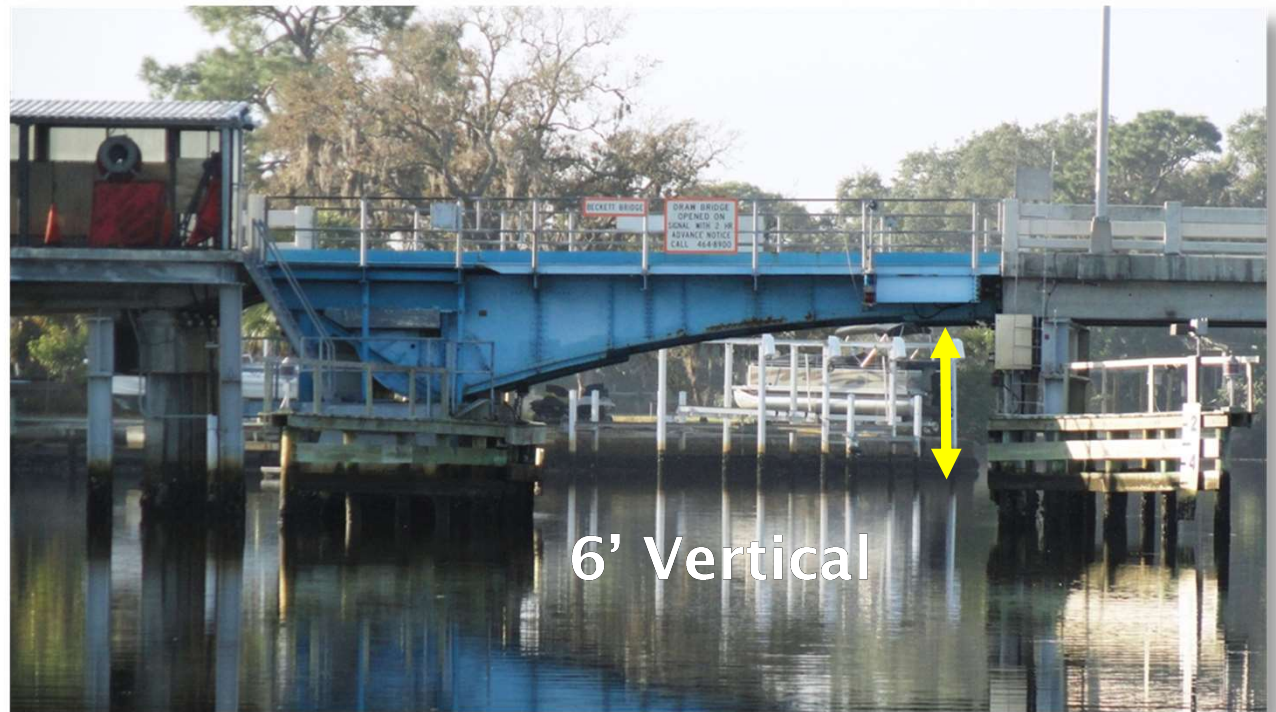

Proposed Bridge

Replacement of Bascule Bridge with New Bascule Bridge

- Replaced on same alignment
- Vertical clearance
 - 7.8 ft in closed position
 - Unlimited in open position
- Horizontal clearance: 25 feet
- Proposed bridge ~20.5 ft wider than existing bridge



Existing Bridge Typical Section

- 10-ft travel lanes
- No Shoulders
- Very Narrow sidewalks
- Overall Width: 28 ft

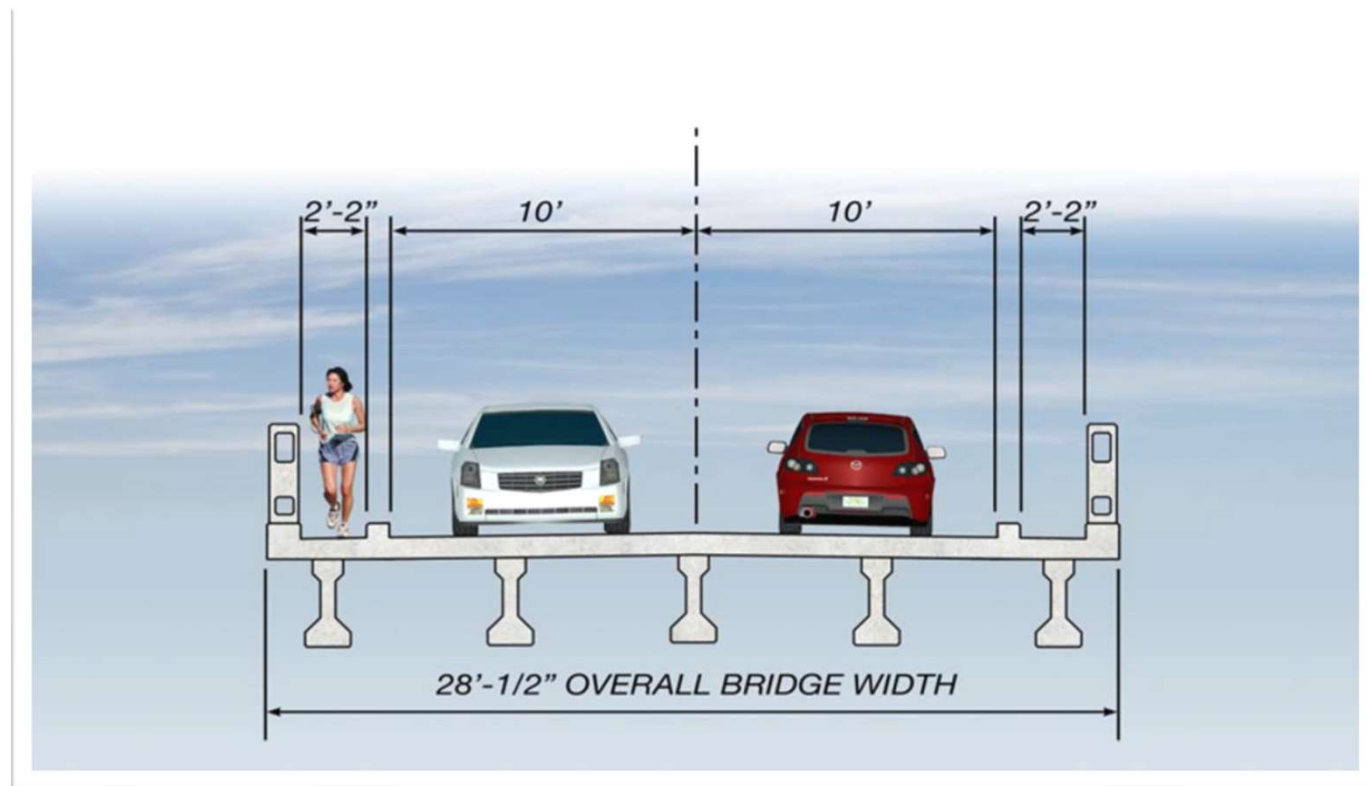

Proposed Bridge Typical Section



- 10ft travel lanes
- 6.5 ft shoulders on both sides
- 6.5 ft sidewalks on both Sides
- Overall width: 48'7"

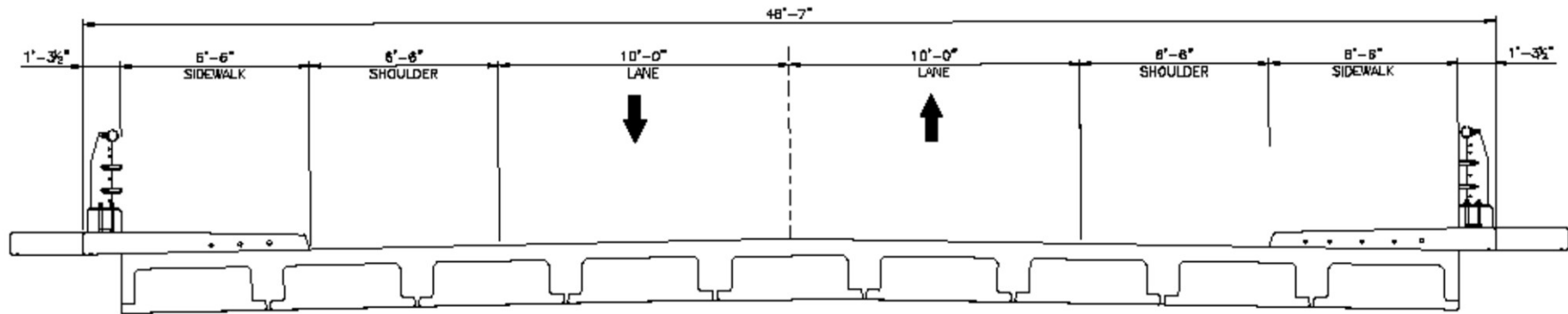

Proposed Roadway Typical Section



East of Bridge

- 10-ft travel lanes
- 6-ft sidewalks on both sides
- 4-ft shoulders

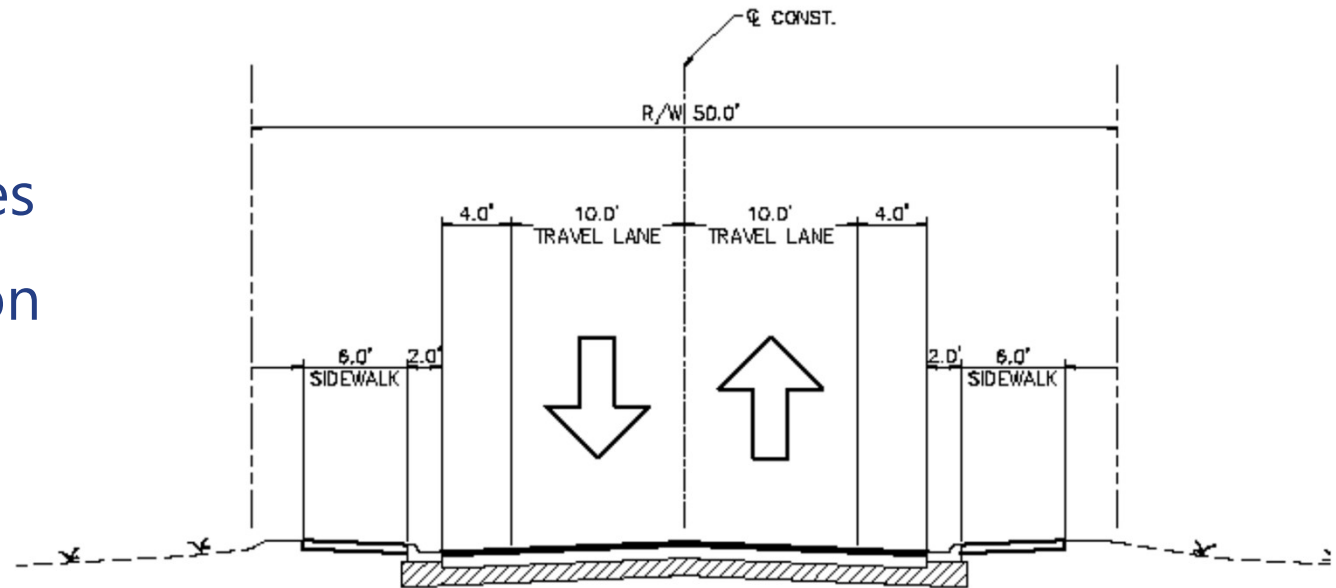

Proposed Roadway Typical Section



West of Bridge

- 10-ft travel lanes
- 6-ft sidewalk on one side
- 4-ft shoulders

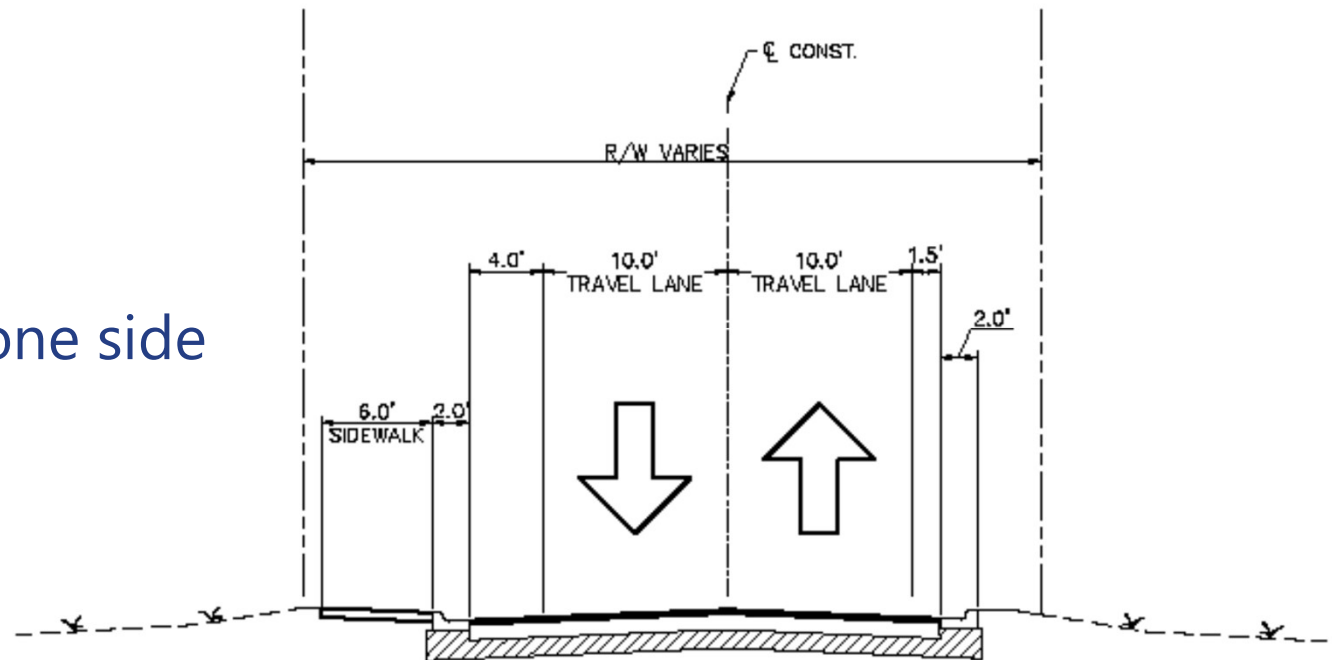

Utilities



Relocation of City Water and Sanitary Sewer Mains

- Utilities crossing Whitcomb Bayou under the existing bridge
- Will be relocated to cross Bayou north of Yacht Club
- Design and Construction, City of Tarpon Springs

Utility Adjustments – West of Bridge

- Design, City of Tarpon Springs
- Joint Project Agreement with Pinellas County
- Construction is included in County's Contract

Construction Easements



Temporary Construction Easements: Approximately 0.1 acre total

- Removal of trees
 - Within the limits of construction
 - Substantial root damage anticipated from construction
- Access for construction of sidewalks/new driveways/curb and gutter

Permanent Easements: Approximately 0.26 acre total

- Outfall for new drainage system (Riverside Drive)
- Tie into existing roadway grades

Funding



Bridge Replacement

- Currently Funded by Penny for Pinellas
- Application for Federal Highway Bridge Improvement Grant
 - Submitted September 8, 2022
 - Expect status of possible grant award late November 2022
 - **Includes City's cost of utility adjustments and relocation**

Riverside Drive Drainage Improvements

- Funded by Penny for Pinellas

Current Project Status – Both Projects



Construction Plans

- Final Design Plans – December 2022

Acquisition of Construction Easements

- Ongoing

Anticipated Advertisement for Construction

- Spring 2023

Anticipated Start of Construction

- Winter 2023

Construction Duration

- 21 Months



Public Outreach



Project Website

- Anticipated project schedule
- Architectural renderings of proposed bridge
- Google Search "Pinellas County Beckett Bridge"

Pre-construction Public Meeting

- To be scheduled after contractor on board
- Anticipated winter 2023



Questions?